



Gas Stove Range





Winchester
Gas Stove



York Midi
Gas Stove



Canterbury
Slimline Gas Stove



Lincoln
Slimline Gas Stove

Cast Iron Gas Stoves

There is nothing more relaxing or comforting than the warm, welcoming glow of a fire.

We at Broseley Fires should know, we are a family run company with more than thirty-five years experience in designing, developing and manufacturing home heating appliances. Our design team has a passion for creating stoves which combine tradition and elegance with realism and efficiency.

Broseley Fires have become a household name in the stove industry, originally proving our expertise by developing appliances for other manufacturers. More recently we have used this renowned experience to launch our own ranges of Multifuel (wood and coal), Gas and Electric Stoves.









Shown with black airwash slider,
black handle and coal effect

Winchester
Gas Stove

Winchester Gas Stove

FUEL TYPE	HEAT OUTPUT	WEIGHT	COLOUR	ENAMEL COLOUR RANGE
NATURAL GAS OR LPG	5.5 Kw	76 Kg	 COMES AS STANDARD	   BY SPECIAL REQUEST

DIMENSIONS

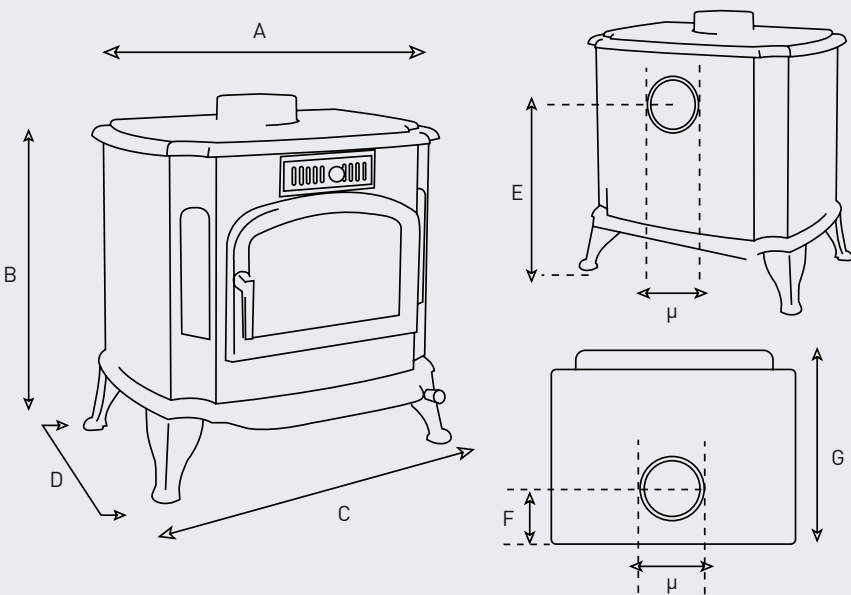

WINCHESTER
 A: 575mm
 B: 590mm
 C: 590mm
 D: 395mm
 E: 460mm
 F: 150mm
 G: 460mm*
 ø: 125mm (5")

* Overall depth including ashlip

FEATURES WINCHESTER

- Triple aspect viewing window
- Selection of door furniture
- Optional top or rear flue
- Oxygen depletion pilot system for safety, which will automatically shut off the appliance should any dangerous fumes be detected
- Fits all British standard fireplaces, Class I, II and pre-cast flue blocks
- Digital Thermostatic remote control fitted as standard
- 80% efficient - no air vent required
- No additional ventilation required
- Full manual control
- Also available in electric and multifuel



Shown with black handles
and plain door

York Midi
Gas Stove

York Midi Gas Stove

FUEL TYPE	HEAT OUTPUT	WEIGHT	COLOUR
NATURAL GAS OR LPG	4.6 Kw	65 Kg	 COMES AS STANDARD

DIMENSIONS

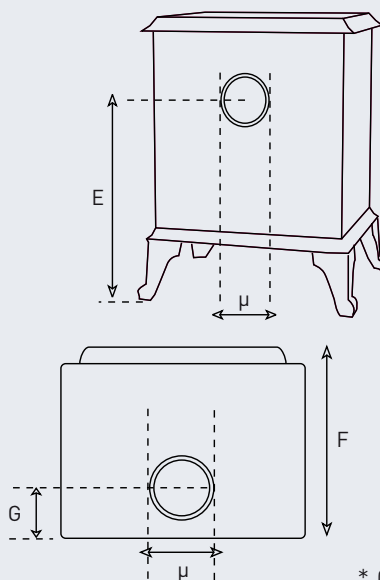
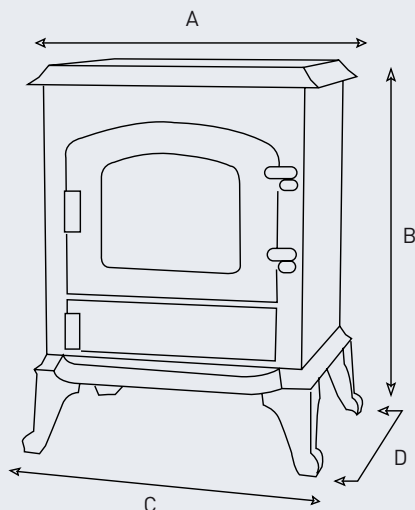

YORK MIDI

- A: 460mm
- B: 584mm
- C: 465mm
- D: 410mm
- E: 470mm
- F: 440mm*
- G: 135mm
- ø: 125mm (5")

* Overall depth including ashtray

FEATURES YORK MIDI





- Optional door designs
- Selection of door furniture
- Optional top or rear flue
- Oxygen depletion pilot system for safety, which will automatically shut off the appliance should any dangerous fumes be detected
- Fits all British standard fireplaces, Class I, II and pre-cast flue blocks
- Digital Thermostatic remote control fitted as standard
- 80% efficient - no air vent required
- No additional ventilation required
- Also available in electric and multifuel
- Coal effect only



Shown with black handles
and Arched window

Canterbury
Slimline Gas Stove

Canterbury Slimline Gas Stove

FUEL TYPE	HEAT OUTPUT	WEIGHT	COLOUR	ENAMEL COLOUR RANGE
NATURAL GAS OR LPG	4.6 Kw	65 Kg	 COMES AS STANDARD	   BY SPECIAL REQUEST

DIMENSIONS

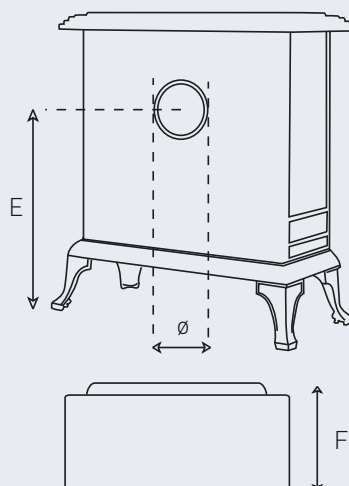
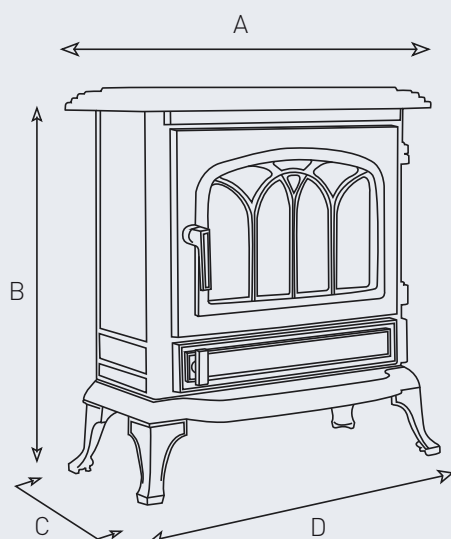

CANTERBURY

A: 575mm
 B: 660mm
 C: 265mm
 D: 600mm
 E: 460mm
 F: 330mm*
 ø: 125mm (5")

* Overall depth including ashlip

GAS STOVE COLLECTION

FEATURES CANTERBURY

- Optional door designs
- Selection of door furniture
- Slimline design fits all standard hearths and fireplaces
- Oxygen depletion pilot system for safety, which will automatically shut off the appliance should any dangerous fumes be detected
- Fits all British standard fireplaces, Class I, II and pre-cast flue blocks
- 80% efficient - no air vent required
- No additional ventilation required
- Rear outlet only
- Also available in electric
- Manual rotary control fitted as standard
- Coal effect only

INSTALLATION CANTERBURY

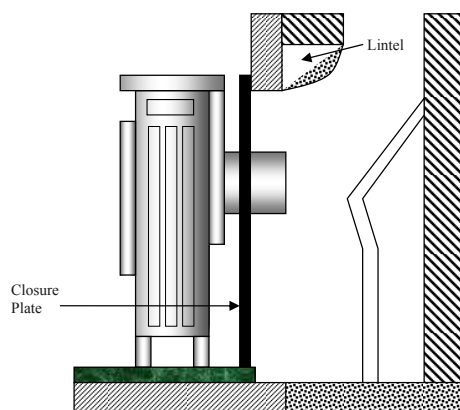



The above drawing shows a typical installation of a Canterbury slimline gas stove on a shallow depth hearth. A vertical closure plate has been used to seal the fireplace opening.



Shown with black handles
and Arched window

Lincoln
Slimline Gas Stove

Lincoln Slimline Gas Stove

FUEL TYPE	HEAT OUTPUT	WEIGHT	COLOUR	ENAMEL COLOUR RANGE
NATURAL GAS OR LPG	4.6 Kw	65 Kg	 COMES AS STANDARD	   BY SPECIAL REQUEST

DIMENSIONS

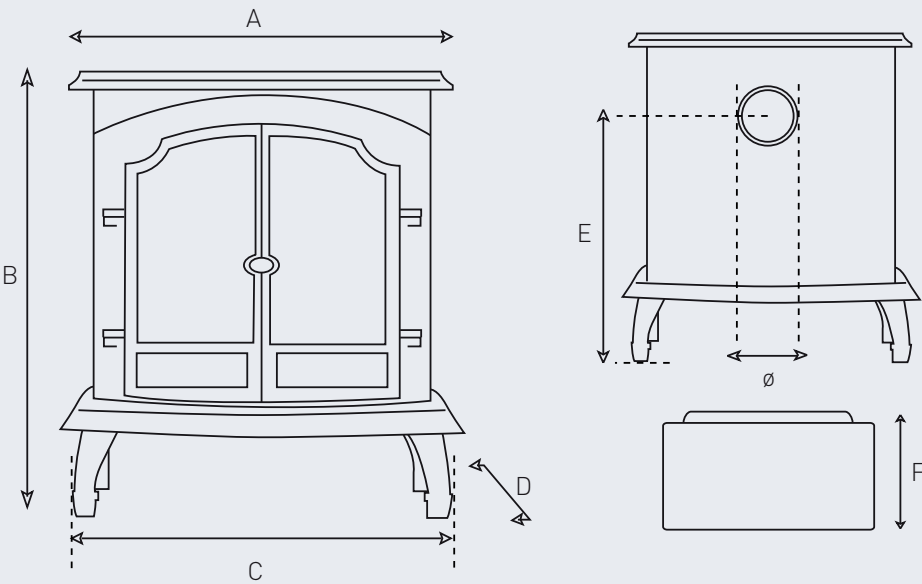

LINCOLN
 A: 570mm
 B: 660mm
 C: 560mm
 D: 220mm
 E: 475mm
 F: 320mm*
 ø: 125mm 5"

* Overall depth including ashlip

FEATURES LINCOLN

- Slimline design fits all standard hearths and fireplaces
- Can be run with double doors open
- Oxygen depletion pilot system for safety, which will automatically shut off the appliance should any dangerous fumes be detected
- Fits all British standard fireplaces, Class I, II and pre-cast flue blocks
- 80% efficient - no air vent required
- No additional ventilation required
- Rear outlet only
- Also available in electric
- Manual rotary control fitted as standard
- Coal effect only

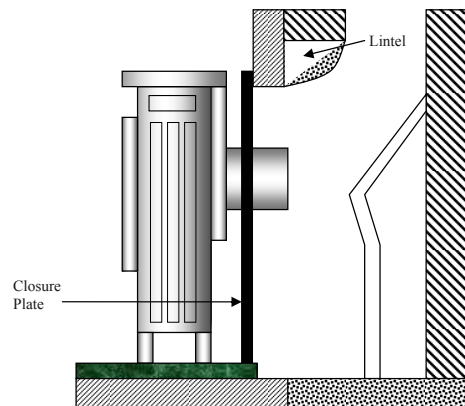

INSTALLATION LINCOLN



The above drawing shows a typical installation of a Lincoln slimline gas stove on a shallow depth hearth. A vertical closure plate has been used to seal the fireplace opening.

Cast Iron Gas Stoves

OPTIONAL EXTRAS

	FUEL EFFECT		LEGS		HANDLES & KNOBS		DOOR INSERTS				Digital Remote Control	ENAMEL FINISH BY SPECIAL REQUEST		
	Coal	Log	Short 5"	Long 10"	Black	Brass	Lattice	Arched Lattice	Plain	Arched Window				
WINCHESTER	●	○	●		●	○			●		●	○	○	○
YORK MIDI	●		●	○	●	○	●	○	○	○	●			
CANTERBURY	●		●		●	○		○	○	●		○	○	○
LINCOLN	●		●									○	○	○

DOOR INSERT OPTIONS



Arched Window



Plain



Arched Lattice



Lattice

"We are a family run company with more than thirty five years experience in designing, developing and manufacturing home heating appliances".

Modern Technology

In the modern world of the 21st century, individual craftsmanship is being eroded by the requirements for standardisation and measurements of quality and safety. We at Broseley Fires have been able to achieve all of these requirements by using traditional castings to construct complete heating appliances that are then tested and approved to the highest European standards.

We have invested heavily into establishing a research and development laboratory. Our engineers are able to test Gas, Multifuel and Electrical appliances using the latest analysers, calibrated fuels and instrumentation to ensure each and every product meets the requirements of European (C.E) Standardisation and approval.

Traditional Casting

Experience has taught us that our customers want to balance the aesthetics of their chosen appliance with practicality. We have endeavoured to create stoves which are not only designed to suit the style of your living room, but are built to stand the test of time. We believe in using long-established materials, such as cast iron, as the material to craft our stoves from.

Cast iron has been used for centuries for its excellent ability to convect and radiate heat. Only cast iron allows the creation of intricate pattern work that cannot be matched by any other material, therefore it remains a material unrivalled in stove manufacture.

This classical range has been developed from four individual stoves the Canterbury, Winchester, Salisbury and York. We believe this range encompasses a wide variety of customer tastes and requirements for the homeowner to choose from when buying a cast iron stove.

We are proud that our gas stoves incorporate all of the strengths that make Broseley Fires a recognized brand. The entire stove body is made from decorative cast iron, to the same strength and quality as our multifuel models. The burner, the artificial log and coal ceramics have been developed to enable the original installation and future servicing of these appliances to be as straightforward as possible.

These appliances will not only serve you well, but they will do so with the minimum of maintenance, maximum of efficiency and will add beauty and warmth to your home for many, many years to come.

FURTHER RANGES OF STOVES FROM BROSELEY FIRES



CAST IRON
ELECTRIC
STOVES



HERCULES
MULTIFUEL
STOVES



THURCROFT
PORTABLE GAS
STOVES



CATHEDRAL
MULTIFUEL
STOVES



ELECTRIC
INSET FIRE
COLLECTION



VERONA
MULTIFUEL
STOVES



RANGE
COOKER
COLLECTION

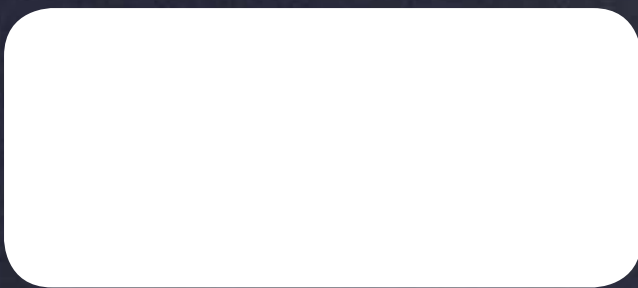

Broseley Fires Ltd reserve the right to alter design and specification without prior notice.

Broseley Fires Limited

Knights Way, Battlefield Enterprise Park
Shrewsbury SY1 3AB

Telephone: +44 (0) 1743 461 444

Fax: +44 (0) 1743 461 446

www.broseleyfires.com